

THE BENDING OF AN ANISOTROPIC PLATE WITH A CENTRAL CIRCULAR CAVITY AND TWO RECTILINEAR CUTS†

S. A. KULIYEV

Baku

(Received 17 January 1991)

The problem of the bending of an anisotropic plate bounded on the outside by an elliptic contour and on the inside by a circular contour with two adjoining cuts of the same length is considered in the classical formulation. In view of the fact that the region occupied by the section of the plate is doubly connected, the required construction of the function which realizes a conformal transformation (using known schemes) meets with considerable difficulties. Using Faber polynomials, it is found to be possible to limit the functions which map the exterior of each of the boundary contours independently, and the exterior of the internal contour is mapped approximately (by retaining a finite number of terms in the expansion). The problem is reduced to solving four systems of infinite linear algebraic equations. A numerical example for an orthotropic plate is considered.

CONSIDER the bending of an anisotropic plate of thickness h , the middle plane of which is a doubly connected region bounded on the outside by an ellipse L_2 with semiaxes a and b , and on the inside by a circle L_1 of radius r with two rectilinear cuts along the abscissa axis (Fig. 1). The origin of coordinates is at the centre of the circle L_1 . The coordinates of the end points of the cut are denoted by $\pm e$. We will assume that at each point of the plate there is a plane of elastic symmetry parallel to the middle plane.

As in the case of an isotropic plate, the solution of the problem is based on Kirchhoff's hypothesis. The edge of the plate can be rigidly clamped, supported by a hinge and free from external forces, or loaded with bending moments and intersecting forces.

The exterior of the outer contour L_2 (the ellipse) is mapped onto the exterior of the unit circle by means of the function

$$z = A_2 \left(\xi_2 + \frac{m_2}{\xi_2} \right), \quad A_2 = \frac{a_2 + b_2}{2}, \quad m_2 = \frac{a_2 - b_2}{a_2 + b_2} \quad (1)$$

The function inverse to (1) has the form

$$\xi_2 = \chi(z) = (z/A_2) \sum a_n^{(1)} (A_2/z)^{2n} \quad (2)$$

Here and everywhere henceforth the summation over n is from $n=0$ to $n=\infty$.

The quantities $a_n^{(1)}$ are defined by well-known formulae [1–5]. The exterior of the internal contour L_1 (the circle with two cuts) is mapped onto the exterior of the unit circle by the function [3–5]

$$z = r \gamma_{-1} \xi_1 \sum \gamma_{n-1}^{(1)} \xi_1^{-n} \quad (3)$$

†*Prikl. Mat. Mekh.* Vol. 57, No. 2, pp. 168–175, 1993.

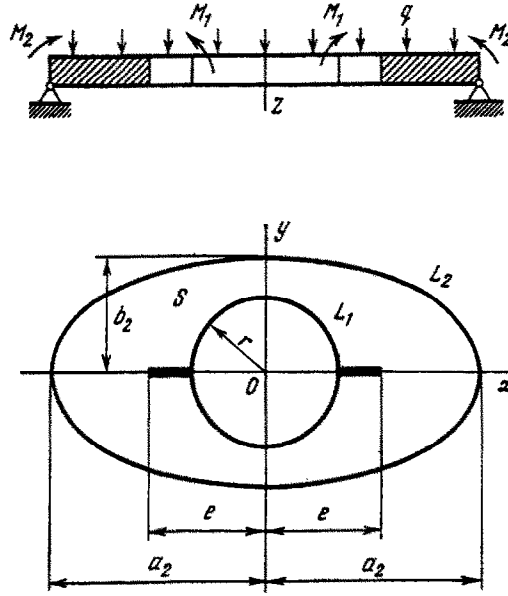

FIG. 1.

The function $\zeta_1 = f(z)$, inverse to the expansion (3), is

$$\xi_1 = \chi(z_1) = (z/r)\delta_{-1} \sum \delta_{n-1}^{(1)} (r/z)^n \tag{4}$$

The fundamental equation of the technical theory of bending of thin anisotropic plates has the form [6-10]

$$D_{11} \frac{\partial^4 \omega}{\partial x^4} + 4D_{16} \frac{\partial^4 \omega}{\partial x^3 \partial y} + 2(D_{12} + 2D_{66}) \frac{\partial^4 \omega}{\partial x^2 \partial y^2} + 4D_{26} \frac{\partial^4 \omega}{\partial x \partial y^3} + D_{22} \frac{\partial^4 \omega}{\partial y^4} = q \tag{5}$$

Here q is a uniformly distributed load and D_{ij} ($i, j = 1, 2, 6$) are the stiffnesses of the plate, which can be expressed in terms of the elastic constants a_{ij} .

We will represent the general solution of Eq. (5) in the form of the sum of its particular and general solutions of the corresponding homogeneous equation, defined by the roots of the characteristic equation. It was shown in [2, 10], that the roots of this equation for actual anisotropic materials are complex or purely imaginary. In general we have

$$\mu_j = \alpha_j + i\beta_j \quad (j=1,2), \quad \mu_3 = \bar{\mu}_1, \quad \mu_4 = \bar{\mu}_2 \tag{6}$$

The complex parameters μ_j ($j = 1, 2$) are called the parameters of the bending of plates. The general real integral of Eq. (5) can be written in the form

$$\omega = \frac{qx^4}{24D_{11}} + 2\text{Re}[\omega_1(z_1) + \omega_2(z_2)] \tag{7}$$

Here $\omega_1(z_1)$ and $\omega_2(z_2)$ are analytic functions of the generalized complex variables z_j ($j = 1, 2$). Here the generalized (or complicated) complex variables z_j are obtained from the ordinary complex variable z by the following affine transformations

$$z_j = x_j + iy_j = x + \mu_j y, \quad x_j = x + \alpha_j y, \quad y_j = \beta_j y \tag{8}$$

The variable $z = x + iy$ relates to the region S (the initial region of the plate), while the variables z_1 and

z_2 refer to the regions S_1 and S_2 , obtained from S by the affine transformation (8).

Hence, the bending of an anisotropic plate (in the final analysis the bending moments, the intersecting forces and the stresses) can be expressed in terms of two analytical functions $w_j(z_j)$ ($j=1, 2$). It should be noted that the same pattern is also observed in the case of the plane problem for an anisotropic solid.

Using the affine transformations (8) the external contour L_2 can be converted and also becomes an ellipse with axes

$$b_2^{(j)} = \beta_j b_2, \quad a_2^{(j)} = a_2 + \alpha_j b_2$$

The function which maps the exterior L_{2j} ($j=1, 2$) (i.e. the exterior of the transformed ellipses), onto the external unit circle has the form [7-10]

$$z_j = A_{2j} \left(\xi_{2j} + \frac{m_{2j}}{\xi_{2j}} \right), \quad A_{2j} = \frac{a_2 - i\mu_j b_2}{2}, \quad m_{2j} = \frac{a_2 + i\mu_j b_2}{a_2 - i\mu_j b_2}$$

The internal contour L_1 is also converted into an ellipse with two cuts along the abscissa axis and semiaxes

$$a_1^{(j)} = r(1 + \alpha_j), \quad b_1^{(j)} = \beta_j r$$

The function which maps the exteriors of the contours L_{2j} (i.e. the exteriors of the ellipses with two cuts) into the exterior of the unit circle, can be represented in the form [3-5]

$$z_j = A_{2j} \xi_{2j} \sum \Pi_{nj} \xi_{2j}^{-n} \tag{9}$$

The functions $\omega_j(z_j)$ depend on the form of the clamping of the edge of the plate, and also on the form of the forces acting on it.

In particular, if the edge of the plate is loaded with bending moments $m(S)$ and intersecting forces $p(S)$, the boundary conditions on the contours L_j for determining the functions $\omega_j(z_j)$ will have the form [6, 7]

$$2 \operatorname{Re}[p_1 \mu_1^{-1} \varphi(z_1) + p_2 \mu_2^{-1} \psi(z_2)] = \varphi_1(S) \tag{10}$$

$$2 \operatorname{Re}[q_1 \varphi(z_1) + q_2 \psi(z_2)] = \varphi_2(S)$$

Here

$$\varphi(z_1) = d\omega_1(z_1) / dz_1, \quad \psi(z_2) = d\omega_2(z_2) / dz_2$$

$$\varphi_1(S) = \int_0^S [f_1 dS - m dy - f dx] + C_1 x + C_{01}$$

$$\varphi_2(S) = -\int_0^S [f_2 dS + m dx - f dy] + C_1 y + C_{02} \tag{11}$$

If bending moments of intensity $m(S)$ are distributed uniformly along the external contour L_2 , we have

$$\varphi_1(S) = -my, \quad \varphi_2(S) = -mx, \quad f_1 = f_2 = 0 \tag{12}$$

On the internal contour (i.e. on the circle with two cuts) in this case we will have $m=0$, $f=0$, and $f_1 = f_2 = 0$.

If the internal contour L_1 is loaded with a constant bending moment of intensity m , while the external contour is free from external forces, we have

$$\text{on } L_2: \quad m=0, \quad f=0, \quad f_1 = f_2 = 0$$

$$\begin{aligned} \text{on } L_1: \quad \varphi_1(S) &= \int_0^S m dy + C_1 x = my + C_1 x \\ \varphi_2(S) &= -\int_0^S m dx + C_1 y = -mx + C_1 y \end{aligned} \quad (13)$$

If normal forces of intensity p act on the external contour of the plate which bend it, Eqs (11) become

$$\begin{aligned} \varphi_1(S) &= \mu_1 d p_2 \int_0^S f dy - \mu_1 d \mu_2 q_2 \left(-\int_0^S f dx \right) \\ \varphi_2(S) &= \mu_2 d (p_1 \varphi_2 - \mu_1 q_1 \varphi_1) \\ f &= \int_0^S p(S) dS, \quad p(S) = p, \quad f = pt \end{aligned} \quad (14)$$

The boundary conditions (10) can sometimes be more conveniently represented in the form [7]

$$\begin{aligned} \varphi(t_1) + K_{12} \overline{\varphi(t_1)} + K_{22} \overline{\psi(t_2)} &= f_{1j} + C(\alpha_1 x + \alpha_2 y) \\ \psi(t_2) + K_{32} \overline{\varphi(t_1)} + K_{42} \overline{\psi(t_2)} &= f_{2j} + C(\alpha_3 x + \alpha_4 y) \\ f_{k2} &= \mu_k d [p_k \varphi_2 - \mu_2 q_2 \varphi_k], \quad k=1,2; \quad p_{22} = p_{42} = K_{42} \end{aligned} \quad (15)$$

where the functions $\varphi_1(S)$ and $\varphi_2(S)$ are defined by (11).

If one of the contours of the plate is rigidly clamped, the following conditions must be satisfied on this contour (instead of the requirement that the bending of the plate should be zero)

$$\partial \omega / \partial x = 0, \quad \partial \omega / \partial y = 0$$

Taking expressions (7) and (11) into account in these conditions, we can reduce the boundary conditions for determining the functions $\varphi(z_1)$ and $\psi(z_2)$ on the clamped edge to the form [7, 9]

$$\begin{aligned} \varphi(t_1) + K_{11} \overline{\varphi(t_1)} + K_{21} \overline{\psi(t_2)} &= f_1^{(1)} \\ \psi(t_2) + K_{31} \overline{\varphi(t_1)} + K_{41} \overline{\psi(t_2)} &= f_2^{(1)} \end{aligned} \quad (16)$$

If the internal contour is rigidly clamped, then in (15) and (16)

$$\begin{aligned} K_{j1} &= (\bar{\mu}_j - \mu_2) / (\mu_1 - \mu_2), \quad e = 0, \quad p_{j1} = K_{j1} \\ K_{2+j1} &= (\mu_1 - \bar{\mu}_j) / (\mu_1 - \mu_2), \quad p_{2j} = K_{2+j1}, \quad j=1,2 \end{aligned} \quad (17)$$

If the external contour is rigidly clamped, we have

$$p_{1j} = K_{j2}, \quad p_{21} = K_{32}, \quad p_{23} = K_{42}, \quad p_{31} = K_{11}, \quad p_{32} = K_{21}, \quad p_{4j} = K_{j+1} \quad (18)$$

If the plates are bent under the action of a normal load of intensity Q , uniformly distributed over the upper surfaces, we have

$$\begin{aligned} \omega_0 &= qx^4 / (24D_{11}) \\ f_1^{(1)} &= \left(\mu_2 \frac{\partial \omega_0}{\partial x} - \frac{\partial \omega_0}{\partial y} \right) \frac{1}{\mu_1 - \mu_2} \\ f_2^{(2)} &= \left(\mu_1 \frac{\partial \omega_0}{\partial x} - \frac{\partial \omega_0}{\partial y} \right) \frac{1}{\mu_1 - \mu_2} \end{aligned} \quad (19)$$

We than have [6, 7]

$$\varphi(t_1) = M_1 \ln z_1 + \varphi_*(t_1), \quad \psi(t_2) = M_2 \ln z_2 + \psi_*(t_2) \tag{20}$$

The coefficients (complex constants) N_1 and N_2 are found from the conditions

$$\begin{aligned} \sum_{j=1}^2 (M_j - \overline{M_j}) &= 0, \quad \sum_{j=0}^2 (\mu_j M_j - \overline{\mu_j} \overline{M_j}) = 0 \\ \sum_{j=1}^{\infty} (\mu_j^2 M_j - \overline{\mu_j^2} \overline{M_j}) &= 0 \\ \sum_{j=1}^2 \left(\frac{M_j}{\mu_j} - \frac{\overline{M_j}}{\overline{\mu_j}} \right) &= -\frac{qa_1^2 C_1}{2iD_{11}} \end{aligned} \tag{21}$$

Hence, the solution of the problem of the bending of anisotropic plates (one edge of which is rigidly clamped) reduces to determining two functions $\varphi(z_1)$ and $\psi(z_2)$ which satisfy boundary conditions (10) and (16).

The functions $\varphi(z_1)$ and $\psi(z_2)$, which are regular in regions S_1 and S_2 , respectively, will be sought in the form [1-5]

$$\begin{aligned} \varphi(z_1) &= \sum \alpha_n \xi_{11}^{-n} + \sum b_n \left(\frac{z_1}{A_2^{(1)}} \right)^n \\ \psi(z_2) &= \sum d_n \xi_{21}^{-n} + \sum c_n \left(\frac{z_2}{A_2^{(2)}} \right)^n \\ b_k &= \sum_{v=k}^{\infty} \beta_v a_{v-k/2}^{(k)}, \quad c_k = \sum_{v=k}^{\infty} c_v h_{v-k/2}^{(k)} \end{aligned} \tag{22}$$

The quantities $a_n^{(k)}$ and $h_n^{(k)}$ are found for each specific contour [3-5].

On the internal contours we have (taking the mapping function (9) into account in (22))

$$\begin{aligned} \varphi(t_1) &= \sum \alpha_n \tau^{-n} + \sum \tau^n H_1(n) + \sum \tau^{-n} H_2(n) \text{ on } L_{11} \\ \psi(t_2) &= \sum d_n \tau^{-n} + \sum \tau^n H_3(n) + \sum \tau^{-n} H_4(n) \text{ on } L_{12} \end{aligned} \tag{23}$$

Here we have also taken into account that one end and the same point on the unit circle corresponds to points z_j of the contours L_{1j} .

The constant C_1 (11), (13) and (21) is found from the condition for the bending ω of the middle plane of the plate to be unique. For an infinite region $C_1 = 0$.

On the external transformed contours L_{2j} we have

$$\varphi_1(t_1) = \sum \alpha_n \xi_{11}^{-n} + \sum b_n (t_1 / A_2^{(j)})^k \text{ on } L_{21} \tag{24}$$

$$\psi(t_2) = \sum D_k (A_1^{(2)} / t_2)^k + \sum c_k (t_2 / A_1^{(2)})^k \text{ on } L_{22} \tag{25}$$

Substituting the mapping functions into (24) and (25), we obtain after some reduction

$$\begin{aligned} \varphi(z_1) &= \sum_{v=0}^{\infty} \tau^{-v} V_1(v) + \sum_{v=0}^{\infty} \tau^v V_2(v) + \sum_{v=0}^{\infty} \tau^{-v} V_3(v) \text{ on } L_{21} \\ \psi(z_2) &= \sum_{v=0}^{\infty} \tau^{-v} V_4(v) + \sum_{v=0}^{\infty} \tau^v V_5(v) + \sum_{v=0}^{\infty} \tau^{-v} V_6(v) \text{ on } L_{22} \end{aligned} \tag{26}$$

The values of all the quantities in (23)-(26) are found in the same way as in [3-5].

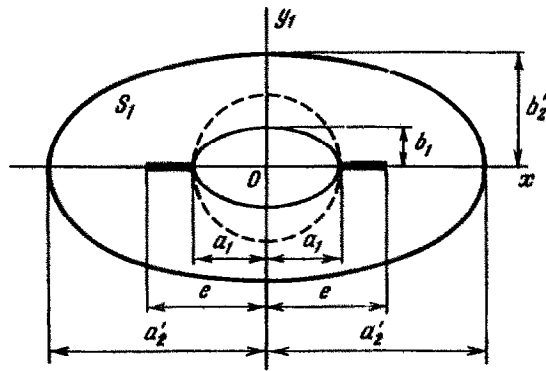

FIG. 2.

Taking (23) and (26) into account in succession in the boundary conditions (10) we obtain four systems of equations (changing to the variable τ).

Equating the coefficients of the same powers of the variable τ , we obtain the following four systems of infinite linear algebraic equations for determining the coefficient of the expansion of the functions $\phi(z_1)$ and $\psi(z_2)$

$$\frac{p_1}{\mu_1}[\alpha_n + H_1(n) + H_2(n)] + \frac{p_2}{\mu_2}[d_n + H_3(n) + H_4(n)] = f_{11} \text{ on } L_{11} \tag{27}$$

$$q_1[\alpha_n + H_1(n) + H_2(n)] + q_2[d_n + H_3(n) + H_4(n)] = f_{21} \text{ on } L_{12} \tag{28}$$

$$\frac{p_1}{\mu_1}[V_1(v) + V_2(v) + V_3(v)] + \frac{p_2}{\mu_2}[V_4(v) + V_5(v) + V_6(v)] = f_{12} \text{ on } L_{21} \tag{29}$$

$$q_1[V_1(v) + V_2(v) + V_3(v)] + q_2[V_4(v) + V_5(v) + V_6(v)] = f_{22} \text{ on } L_{22} \tag{30}$$

Hence, the solution of the problem reduces to solving four systems (27)–(30) of infinite equations in the unknown coefficients α_n, β_n, d_n and c_n .

Taking the first few terms of these equations we find the coefficients α_n, β_n, d_n and c_n . We can further determine the functions $\phi(z_1)$ and $\psi(z_2)$, and then, using (7), we can find the deflection of the plate ω .

We could substitute (23) and (26) into the boundary conditions (15) and (16) and obtain solutions of the problem of the bending of a plate with a single rigidly clamped contour.

After determining the complex potentials $\phi_*(z)$ and $\psi_*(z)$, the stress intensity factors (SIF) near the vertex of the cut for the bending of an anisotropic plate can be calculated from one of the following formulae [6]

$$\mu_1[K_1 p_2 + K_2 q_2 \mu_2] = -\frac{2A}{h^2}(p_1 q_2 \mu_2 - p_2 q_1 \mu_1) \frac{\phi'_*(\tau)}{\sqrt{\omega''(\tau)}} \tag{31}$$

$$\mu_2[K_1 p_1 + K_2 q_1 \mu_1] = -\frac{2A}{h^2}(p_1 \mu_2 q_2 - p_2 q_1 \mu_1) \frac{\psi'_*(\tau)}{\sqrt{\omega''(\tau)}} \tag{32}$$

Here τ is a point on the unit circle which corresponds to the cuspidal point on the contour of the defect (i.e. the cut).

To illustrate the solution obtained we will consider some numerical examples.

1. The bending of an elliptic plate with an elliptic cavity by moments of intensity $m(S) = m$ uniformly distributed over the outer contour. The inner contour is assumed to be rigidly clamped (Fig. 2).

If we take $e = r$ in (27)–(30), then in the transformed cross-sections S_1 , the inner contour will be an ellipse with semi-axes a_{1j} and b_{1j} . From these systems of equations we retained the first five and determined the coefficients of the expansion of the functions $\phi_*(z_1)$ and $\psi_*(z_2)$, i.e. α_k, β_k, c_k and d_k .

TABLE 1

Points, z/a_2	M_x		M_y	
	Plywood	SVAM	Plywood	SVAM
0.2	0.8950	2.5268	0.004	0.3412
0.5	1.2120	1.020	0.8021	1.022
1.0	1.004	1.04	1.024	0.9866
0.1i	0.651	0.1304	2.064	1.004
0.25i	1.721	0.5124	1.1434	1.22
0.5i	1.464	0.7311	1.012	1.022

TABLE 2

Fractions	Version	Glass-epoxy		Graphite-epoxy	
		$\beta = 0$	$\pi/2$	0	$\beta = \pi/2$
$\sigma_x \frac{\sqrt{2r_1} h}{K_1 \delta}$	a	0.46	0.22	0.46	0.22
	b	0.67	0.44	0.64	0.38
$\sigma_y \frac{\sqrt{2r_1} h}{K_1 \delta}$	a	2.0	0.54	2.0	0.44
	b	3.64	1.21	3.81	1.10

Further, from (22) we determined the regular functions $\varphi_*(z_1)$ and $\psi_*(z_2)$, and then from (7), taking (11) into account, we calculated the deflection of the plate w at characteristic points. As in [7, 10] we determined the bending moments and the intersecting forces at characteristic points of the section.

We took plywood as the material of the plate, for which [7, 10]

$$\mu_1 = 1.04 + 1.55i, \quad \mu_2 = -1.04 + 1.55i$$

and also when the plate is made of SVAM for which [7, 10]

$$\mu_1 = 0.442 + 0.899i, \quad \mu_2 = -0.442 + 0.899i$$

The values obtained for the bending moments are shown in Table 1.

The maximum bending in a plywood plate turned out to be approximately six times greater than in a plate of SVAM.

Without appreciable error ($\leq 4\%$) we can assume a plate with parameters $a_2/a_1 = 10$ to be infinite, since the results of bending, the bending moments and the intersecting forces are almost identical with the results for an infinite plate, rigidly clamped along the edge of an elliptic opening [6].

2. The bending of an elliptic plate with a central rectilinear cut acted upon by moments of intensity $m(S) = m$ uniformly distributed over the external contour.

From systems (27) and (30) we retained the first five equations (for $m_1 = 1$ and $b_1 = 0$) and obtained the coefficients α_k , β_k , c_k and d_k .

A numerical calculation was carried out for the ratios

$$(a) a_1/a_2 = 0.2, \quad (b) a_1/a_2 = 0.5.$$

At the end points of the cut, using (32) we determined the stress intensity factors for different materials in the case of pure bending of an orthotropic plate (as in the case of an isotropic plate, $K_2 = 0$).

The results are shown in Table 2, where r_1 is a coordinate in a local polar system, with origin at the tip of the cracks ($r_1 \ll l$, and $l = e - r$ is the length of the cracks).

It should be noted that for a ratio $a_1/a_2 = 0.2$ the values of the stress intensity factors are identical with

the results obtained in [6] for an infinite plate with a rectilinear cut along the abscissa axis.

REFERENCES

1. SHERMAN D. I., A problem in the theory of elasticity. *Dokl. Akad. Nauk SSSR* 27, 907–910, 1940.
2. SHERMAN D. I., A plane problem of the theory of elasticity for an anisotropic medium. *Trudy Seismol. Inst. Akad. Nauk SSSR* 86, 51–77, 1938.
3. KULIYEV S. A., The stress state of a circular plate weakened by a central square opening and two cuts. *Izv. Akad. Nauk SSSR, MTT* 6, 184–190, 1987.
4. KULIYEV S. A., The twisting of a circular beam weakened by two cavities of different form. *Izv. Akad. Nauk SSSR, MTT* 3, 177–191, 1987.
5. KULIYEV S. A., A problem for a doubly connected region of a certain form. *Izv. Akad. Nauk AzSSR. Ser. Fiz. Mat. Tekh. Nauk* 5, 46–53, 1969.
6. BEREZHNIITSKII L. T., DELYAVSKII M. V. and PANASYUK V. V., *The Bending of Thin Plates with Crack-like Defects*. Naukova Dumka, Kiev, 1979.
7. KOSMODAMIANSKII A. S., *The Stress State of Anisotropic Media with Openings or Cavities*. Vyssh. Shkola, Kiev–Donetsk, 1976.
8. MUSKHELISHVILI N. I., *Some Fundamental Problems in the Mathematical Theory of Elasticity*. Nauka, Moscow, 1966.
9. SAVIN G. N., *The Stress Distribution Around Openings*. Naukova Dumka, Kiev, 1968.
10. LEKHNIITSKII S. G., *Anisotropic Plates*. Gostekhizdat, Moscow, 1957.
11. AMENZADE Yu. A., *Theory of Elasticity*. Vyssh. Shkola, Moscow, 1976.

Translated by R.C.G.